



# **SL15, SL60, SL70 & SL70-CS Installation and Service Manual**

Version 3.2



## Table of Contents

<b>Introduction</b>	<b>2</b>
<b>Operating Principle</b>	<b>3</b>
<b>Technology</b>	<b>3</b>
<b>SL15 Model</b>	<b>4</b>
<b>SL60 &amp; SL70 Models</b>	<b>5</b>
<b>Maintenance &amp; Servicing</b>	<b>7</b>
<b>Flash Codes</b>	<b>8</b>
<b>Troubleshooting</b>	<b>15</b>
<b>Sealite Lantern Warranty</b>	<b>16</b>

## Introduction

Congratulations! By choosing to purchase a Sealite lantern you have become the owner of one of the most advanced LED marine lanterns in the world.

Sealite Pty Ltd has been manufacturing lanterns for over 20 years, and particular care has been taken to ensure your lantern gives years of service.

As a commitment to producing the highest quality products for our customers, Sealite has been independently certified as complying with the requirements of **ISO 9001:2000** quality management system.

Sealite lanterns comply with requirements of the US Coast Guard in 33 CFR part 66 for Private Aids To Navigation.

By taking a few moments to browse through this booklet, you will become familiar with the versatility of your lantern, and be able to maximise its operating function.

Please remember to complete the Sealite warranty registration card accompanying your lantern.



## **Operating Principle**

The solar module of the lantern converts sunlight to an electrical current that is used to charge the battery. The battery provides power to operate the lantern at night.

The flasher unit has very low current requirements. A microprocessor drives an array of ultra bright LED's through a DC/DC converter, which enables the LED's to operate within the manufacturer's specifications. The battery is protected from over-charging within the circuit to ensure maximum battery life.

On darkness, the microprocessor will initiate a program check and after approximately 1 minute begin flashing to the set code.

## **Technology**

### **Electronics**

Sealite employs leading in-house electronic engineers in the design and development of software and related circuitry. All individual electronic components are sourced directly by Sealite procurement staff ensuring that only the highest quality components are used in our products.

### **LED Technology**

All marine lanterns use the latest advancements in LED (Light Emitting Diode) technology as a light source. The major advantage of LED's over traditional light sources is well established in that they typically have an operational life in excess of 100,000 hours, resulting in substantial savings to maintenance and servicing costs.

### **Precision Construction**

Commitment to investing in the design and construction of injection-moulded parts including optic lenses, light bases and a range of other components ensures that all Sealite products are of a consistent and superior quality.

### **Optical Performance**

Sealite manufactures a range of marine LED lenses moulded from multi-cavity dies. Complex shapes such as the SL70 lens are a testament to the company's superior in-house lens manufacturing capabilities and outstanding optical performance.

### **Award-winning, Patented Technology**

Several United States and Australian patent registrations are held on Sealite's range of innovative designs, with other regional patents pending in Canada, United Kingdom and Europe.

## SL15 Model

The Sealite SL15 1nm LED compact light incorporates some of the most advanced technology available. Designed to be maintenance-free and have a service life of over 5 years, the Sealite SL15 is supplied ready for installation, and requires no operator intervention.

An optional ON/OFF switch can be installed on request (additional charges may apply).

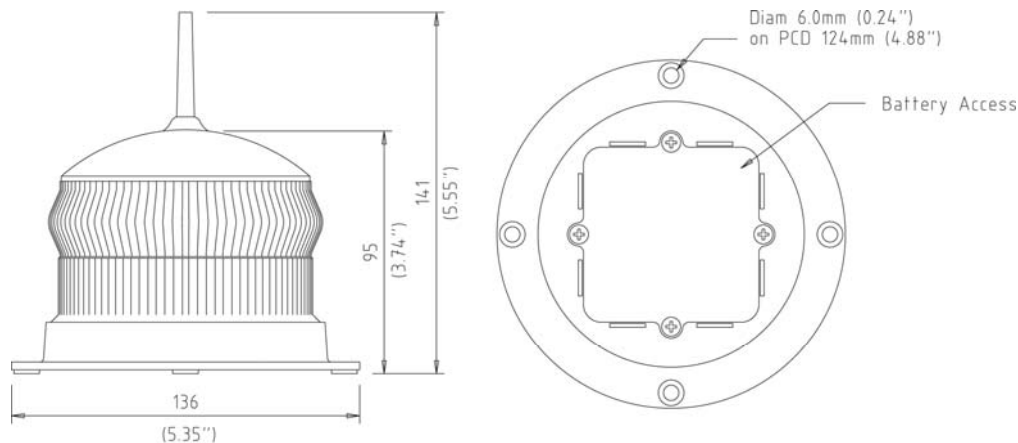

### Installation of SL15 Model

1. After 16 hours of continuous darkness, the unit will enter a storage mode.
2. Place lantern in sunlight for several hours to ensure battery is fully charged.
3. To test place dark cover (towel or jacket) on top of light to activate sensor, light will come on.
4. The lantern is now ready for installation.
5. Ensure that the unit is bolted to an even, flat surface.

### *Intensity Setting*

Intensity options are available for the Sealite SL15 model, but must be preset during manufacturing.

### *Flash Code*

Sealite's SL15 is set to one of 15 Standard IALA flash characteristics which are pre-set during manufacturing of the product and must be specified on order. Other flash codes are available on request, but may incur an additional cost.

## SL60 & SL70 Models

### SL60

The Sealite SL60 is the most popular and versatile 2nm solar marine light available. Made from tough, durable polycarbonate and using the latest high-intensity LEDs, no expense has been spared in the design and development of this lantern. Installation takes just minutes, and a permanent ON/OFF switch allows for easy storage.

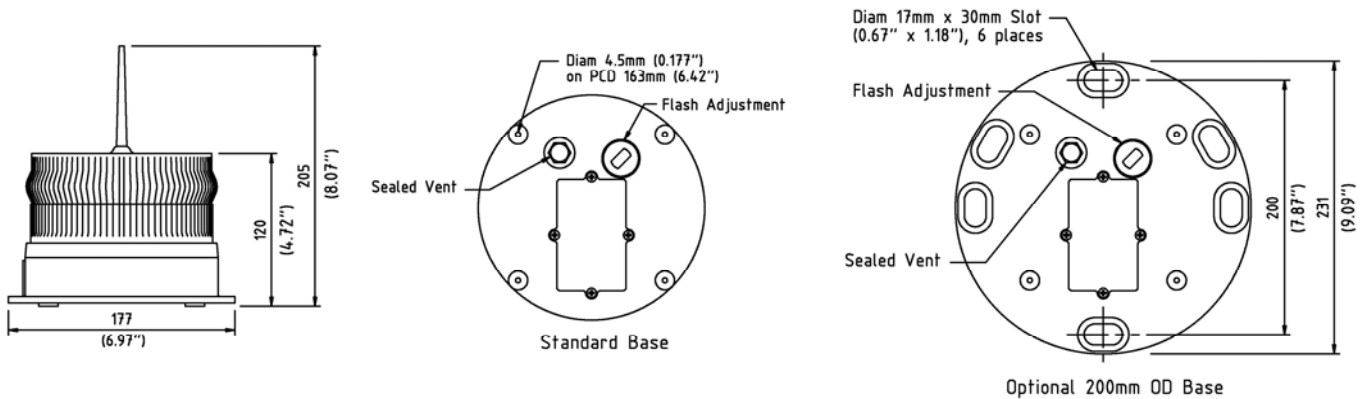

### SL70 & SL70-CS

The Sealite SL70 2.5nm solar marine lantern is exceptional in its unique ability to 'track the sun', operating reliably in low sunlight conditions. Made from tough, durable polycarbonate and using the latest high-intensity LED's, the SL70 lantern boasts dual high-performance solar modules incorporated into Sealite's world-first Solar Collection Lens.

The SL70-CS (Comm-sync) Synchronised solar marine lantern is fitted with an internal RF module that operates on a 2.4Ghz frequency and has an operational range of 1.5km between 2 lights. Should more than two lights be required to be synchronised the range may be extended for longer distances as the lanterns transmit data to the adjacent lantern, causing it to fall in to synchronisation. The only limitation is no lantern should be more than 1.5km from the next lantern in series.

The SL70-CS lanterns operate within a peer to peer network topology and therefore are not dependant upon Master/Slave relationships. Using innovative software, the additional power consumption is minimal and in most configurations the SL70-CS requires only 1.5 hours of direct sunlight per day to retain full working autonomy.

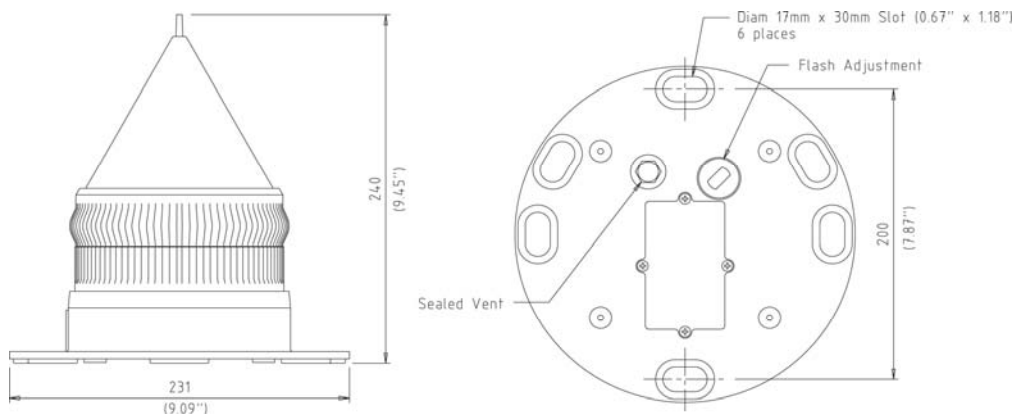

SL70

## Installation of the SL60 & SL70 Models

Lantern is activated by ON/OFF Switch. Intensity and flash settings need to be set prior to activation.

1. Remove the marked flash adjustment bung from the base of the lantern and set internal toggle switch to 'ON'.
2. The power and range settings of the lantern are adjusted by setting the DIP switches inside the lantern. Your lantern is normally set to maximum range (see 'Selecting an Intensity Setting' below).
3. Set rotary switches to the required flash code (see 'Selecting a Flash Code' below).
4. Replace flash adjustment bung.
5. A sealed vent on the base allows air transfer without moisture intake, and should not be disturbed.
6. To test place dark cover (towel or jacket) on top of light to activate sensor, light will come on.
7. Ensure that the unit is bolted to an even, flat surface.

### *Selecting an Intensity Setting*

Pulse settings on Sealite lanterns operate via DIP switches, located near the rotary switches on the flasher unit. The pulse settings may be used to reduce the power consumption and intensity of the lantern. Setting the lantern to 25% pulse will reduce the power consumption to 25% of the normal 100% setting and the range by 50%. This setting may be used to adjust to local sunlight conditions.

The following diagrams indicate pulse settings:-

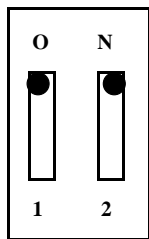

100%

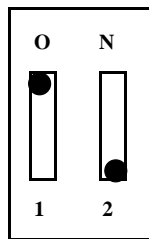

75%

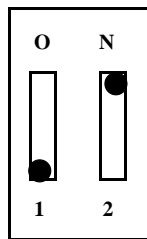

50%

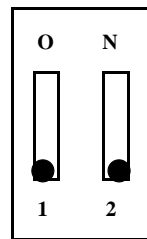

25%

### *Selecting a Flash Code- Rotary Switches A and B*

All lanterns have 2 rotary switches marked A and B on the flasher unit (see top page 7). Turning the small arrows to the appropriate number or letter will set the code (see 'Flash Code' section, page 8). The unit may take up to one minute to activate a new flash code. A comprehensive list of available flash codes is listed on pages 8-14 of this manual.

## Rotary Switches A and B

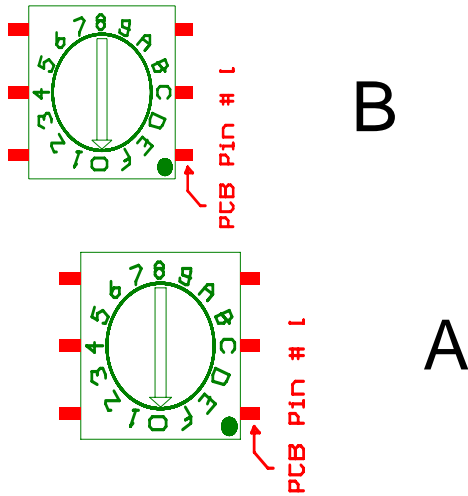

**NOTE: Charging Battery**

New lanterns should be left in the sun for several days to ensure battery is charged before placing in service.

## Maintenance and Servicing

Designed to be maintenance free, the SL15, SL60 and SL70 require minimal attention, though the following maintenance and servicing information is provided to help ensure the life of your Sealite product.

1. Cleaning Solar Panels- occasional cleaning of the solar panels may be required. Using a cloth and warm soapy water, wipe off any foreign matter before rinsing the panels with fresh water.
2. Battery Check- inspection of batteries should be performed every three years (minimum) to ensure that the charger, battery and ancillary electronics are functioning correctly. Using a voltage meter, check that the battery voltage is at least 3.6 volts under 100MA load, and ensure all terminals are clear of foreign matter.

### Replacing the battery- *Don't throw the unit out!!*

The SL15, SL60 & SL70 lanterns are the only compact marine lantern with a double sealed battery compartment. This provides the user with the ability to change the battery after years of operation.

1. Open bung and turn lantern 'OFF' via the internal switch (SL60 and SL70 only).
2. Unscrew small screws to remove battery plate.
3. Remove battery from SL15/SL60/SL70 case and unscrew positive and negative leads.
4. Discard old battery in a safe manner.
5. Reattach positive and negative leads to new battery and then place back into case.
6. Reattach battery plate and switch lantern 'ON' via internal switch. Close the bung (SL60 and SL70 only).
7. To test place dark cover (towel or jacket) on top of light to activate sensor, light will come on.

***Care must be taken to observe the polarity of the battery before the leads are re-connected, and ensure the replacement battery is correctly fitted. Always discard old batteries in a safe manner.***



## Flash Codes

**SEALITE® code reference is listed by number of flashes**

**For the latest version of this document visit [www.sealite.com.au](http://www.sealite.com.au) ,  
or email [info@sealite.com.au](mailto:info@sealite.com.au)**

### Symbols

- FL Flash followed by number Eg. FL 1 S, one flash every second
- F Fixed
- Q Quick flash
- VQ Very quick flash
- OC Occulting; greater period on than off
- ISO Isophase; equal period on and off
- LFL Long flash long
- MO Morse code ( ) contains letter

For example, VQ (6) + LFL 10 S means 6 very quick flashes followed by a long flash, during a 10-second interval.

The amount of power your lantern draws through the night depends on the duty cycle, i.e. the amount of time on as a proportion to the timing cycle. For example, 0.5 seconds on and 4.5 seconds off equals a 10% duty cycle.

It is best to operate at the lowest duty cycle appropriate to the actual needs of the application.

### Recommended Rhythm for Flashing Light - IALA Regions A and B

MARK DESCRIPTION	RHYTHM
<b>Port Hand &amp; Starboard Marks:</b>	Any, other than Composite Group Flashing (2+1)
<b>Preferred Channel Starboard:</b>	Composite Group Flashing (2+1)
<b>Preferred Channel Port:</b>	Composite Group Flashing (2+1)
<b>North Cardinal Mark:</b>	Very quick or quick
<b>East Cardinal Mark:</b>	Very quick (3) every 5 seconds or quick (3) every 10 seconds
<b>South Cardinal Mark:</b>	Very quick (6) + long flash every 10 seconds or quick (6) + long flash every 15 seconds
<b>West Cardinal Mark:</b>	Very quick (9) every 10 seconds or quick (9) every 15 seconds
<b>Isolated Danger Mark:</b>	Group flashing (2)
<b>Safe Water Mark:</b>	Isophase, occulting, one long flash every 10 seconds or Morse Code "A"
<b>Special Marks:</b>	Any, other than those described for Cardinal, Isolated Danger or Safe Water Marks



SWITCH		FLASH CODE	ON	OFF
A	B			
0	0	F (Steady light)		
D	3	VQ 0.5 S	0.2	0.3
E	3	VQ 0.6 S	0.2	0.4
F	3	VQ 0.6 S	0.3	0.3
7	3	Q 1 S	0.2	0.8
8	3	Q 1 S	0.3	0.7
9	3	Q 1 S	0.4	0.6
A	3	Q 1 S	0.5	0.5
8	4	Q 1 S	0.8	0.2
B	3	Q 1.2 S	0.3	0.9
9	4	Q 1.2 S	0.5	0.7
C	3	Q 1.2 S	0.6	0.6
F	4	FL 1.5 S	0.2	1.3
1	0	FL 1.5 S	0.3	1.2
0	5	FL 1.5 S	0.4	1.1
0	4	FL 1.5 S	0.5	1.0
2	0	FL 2 S	0.2	1.8
3	0	FL 2 S	0.3	1.7
4	0	FL 2 S	0.4	1.6
5	0	FL 2 S	0.5	1.5
6	0	FL 2 S	0.7	1.3
7	0	FL 2 S	0.8	1.2
1	2	ISO 2 S	1.0	1.0
8	0	FL 2.5 S	0.3	2.2
9	0	FL 2.5 S	0.5	2.0
D	6	FL 2.5 S	1.0	1.5
1	5	FL 3 S	0.2	2.8
A	0	FL 3 S	0.3	2.7
2	5	FL 3 S	0.4	2.6
B	0	FL 3 S	0.5	2.5
3	5	FL 3 S	0.6	2.4
C	0	FL 3 S	0.7	2.3
D	0	FL 3 S	1.0	2.0
2	2	ISO 3 S	1.5	1.5
5	4	OC 3 S	2.0	1.0
E	2	OC 3 S	2.5	0.5
4	6	OC 3.5 S	2.5	1.0
4	5	FL 4 S	0.2	3.8
5	5	FL 4 S	0.3	3.7
E	0	FL 4 S	0.4	3.6
F	0	FL 4 S	0.5	3.5
6	5	FL 4 S	0.6	3.4
0	1	FL 4 S	0.8	3.2
1	1	FL 4 S	1.0	3.0
2	1	FL 4 S	1.5	2.5
3	2	ISO 4 S	2.0	2.0
3	6	OC 4 S	2.5	1.5
F	2	OC 4 S	3.0	1.0
3	1	FL 4.3 S	1.3	3.0
8	5	FL 5 S	0.2	4.8
4	1	FL 5 S	0.3	4.7
5	1	FL 5 S	0.5	4.5
9	5	FL 5 S	0.9	4.1
6	1	FL 5 S	1.0	4.0
7	1	FL 5 S	1.5	3.5
4	2	ISO 5 S	2.5	2.5
8	2	LFL 5 S	2.0	3.0
0	3	OC 5 S	3.0	2.0

SWITCH		FLASH CODE	ON	OFF
A	B			
1	3	OC 5 S	4.0	1.0
2	3	OC 5 S	4.5	0.5
C	6	FL 6 S	0.2	5.8
B	5	FL 6 S	0.3	5.7
C	5	FL 6 S	0.4	5.6
8	1	FL 6 S	0.5	5.5
9	1	FL 6 S	0.6	5.4
A	1	FL 6 S	1.0	5.0
7	5	FL 6 S	1.2	4.8
B	1	FL 6 S	1.5	4.5
5	2	ISO 6 S	3.0	3.0
9	2	LFL 6 S	2.0	4.0
6	4	OC 6 S	4.0	2.0
3	3	OC 6 S	4.5	1.5
4	3	OC 6 S	5.0	1.0
A	4	FL 7 S	1.0	6.0
9	6	FL 7 S	2.0	5.0
5	6	OC 7 S	4.5	2.5
D	5	FL 7.5 S	0.5	7.0
C	1	FL 7.5 S	0.8	6.7
E	5	FL 8 S	0.5	7.5
B	4	FL 8 S	1.0	7.0
6	2	ISO 8 S	4.0	4.0
A	2	LFL 8 S	2.0	6.0
6	6	OC 8 S	5.0	3.0
B	2	LFL 8 S	3.0	5.0
F	5	FL 9 S	0.9	8.1
C	4	FL 9 S	1.0	8.0
7	6	OC 9 S	6.0	3.0
0	6	FL 10 S	0.2	9.8
1	6	FL 10 S	0.3	9.7
D	1	FL 10 S	0.5	9.5
2	6	FL 10 S	0.8	9.2
E	1	FL 10 S	1.0	9.0
1	4	FL 10 S	1.5	8.5
C	2	LFL 10 S	2.0	8.0
D	2	LFL 10 S	3.0	7.0
7	2	ISO 10 S	5.0	5.0
2	4	LFL 10 S	4.0	6.0
8	6	OC 10 S	6.0	4.0
5	3	OC 10 S	7.0	3.0
6	3	OC 10 S	7.5	2.5
F	1	FL 12 S	1.2	10.8
D	4	FL 12 S	2.5	9.5
3	4	LFL 12 S	2.0	10.0
0	2	FL 15 S	1.0	14.0
4	4	LFL 15 S	4.0	11.0
7	4	OC 15 S	10.0	5.0
A	6	LFL 20 S	2.0	18.0
E	4	FL 26 S	1.0	25.0

SWITCH	FLASH CODE	ON	OFF	ON	OFF
A	B				
0	A	FL (2) 4 S	0.5	1.0	0.5 2.0
E	B	VQ (2) 4 S	0.2	1.0	0.2 2.6
1	A	FL (2) 4.5 S	0.3	1.0	0.3 2.9
2	A	FL (2) 4.5 S	0.4	1.0	0.4 2.7
3	A	FL (2) 4.5 S	0.5	1.0	0.5 2.5
F	9	FL (2) 5 S	0.2	0.8	0.2 3.8
2	C	FL (2) 5 S	0.2	1.2	0.2 3.4
4	A	FL (2) 5 S	0.4	0.6	0.4 3.6
0	7	FL (2) 5 S	0.5	1.0	0.5 3.0
1	7	FL (2) 5 S	1.0	1.0	1.0 2.0
9	B	Q (2) 5 S	0.3	0.7	0.3 3.7
2	9	Q (2) 5 S	0.5	0.5	0.5 3.5
5	A	FL (2) 5.5 S	0.4	1.4	0.4 3.3
7	8	FL (2) 6 S	0.3	0.6	1.0 4.1
A	A	FL (2) 6 S	0.3	0.9	0.3 4.5
6	A	FL (2) 6 S	0.3	1.0	0.3 4.4
7	A	FL (2) 6 S	0.4	1.0	0.4 4.2
9	9	FL (2) 6 S	0.5	1.0	0.5 4.0
2	8	FL (2) 6 S	0.8	1.2	0.8 3.2
3	7	FL (2) 6 S	1.0	1.0	1.0 3.0
3	9	Q (2) 6 S	0.3	0.7	0.3 4.7
A	9	FL (2) 7 S	1.0	1.0	1.0 4.0
7	B	FL (2) 8 S	0.4	0.6	2.0 5.0
8	A	FL (2) 8 S	0.4	1.0	0.4 6.2
4	7	FL (2) 8 S	0.5	1.0	0.5 6.0
8	8	FL (2) 8 S	0.8	1.2	2.4 3.6
5	7	FL (2) 8 S	1.0	1.0	1.0 5.0
4	C	OC (2) 8 S	3.0	2.0	1.0 2.0
5	C	OC (2) 8 S	5.0	1.0	1.0 1.0
F	B	VQ (2) 8 S	0.2	1.0	0.2 6.6
9	A	FL (2) 10 S	0.4	1.6	0.4 7.6
9	8	FL (2) 10 S	0.5	0.5	1.5 7.5
6	7	FL (2) 10 S	0.5	1.0	0.5 8.0
7	7	FL (2) 10 S	0.5	1.5	0.5 7.5
6	9	FL (2) 10 S	0.5	2.0	0.5 7.0
8	7	FL (2) 10 S	0.8	1.2	0.8 7.2
B	9	FL (2) 10 S	1.0	1.0	1.0 7.0
9	7	FL (2) 10 S	1.0	1.5	1.0 6.5
4	9	Q (2) 10 S	0.6	0.4	0.6 8.4
B	A	FL (2) 12 S	0.4	1.0	0.4 10.2
C	9	FL (2) 12 S	0.5	1.0	0.5 10.0
D	9	FL (2) 12 S	1.5	2.0	1.5 7.0
A	8	FL (2) 15 S	0.5	1.5	2.0 11.0
A	7	FL (2) 15 S	1.0	2.0	1.0 11.0
8	B	Q (2) 15 S	0.2	0.8	0.2 13.8
C	A	FL (2) 20 S	1.0	3.0	1.0 15.0
D	A	FL (2) 25 S	1.0	1.0	1.0 22.0

SWITCH	FLASH CODE	ON	OFF	ON	OFF	ON	OFF
A	B						
7	9	Q (3) 5 S	0.5	0.5	0.5	0.5	2.5
5	9	VQ (3) 5 S	0.2	0.3	0.2	0.3	3.8
0	C	VQ (3) 5 S	0.3	0.2	0.3	0.2	3.7
E	9	VQ (3) 5 S	0.3	0.3	0.3	0.3	3.5
3	C	FL (3) 6 S	0.5	1.0	0.5	1.0	2.5
2	B	FL (2+1) 6 S	0.3	0.4	0.3	1.2	3.5
A	B	Q (3) 6 S	0.3	0.7	0.3	0.7	3.7
F	A	FL (3) 8 S	0.5	1.0	0.5	1.0	4.5
0	B	FL (3) 9 S	0.3	1.0	0.3	1.0	6.1
B	7	FL (3) 9 S	0.8	1.2	0.8	1.2	4.2
B	8	FL (3) 10 S	0.3	0.7	0.3	0.7	7.1
C	8	FL (3) 10 S	0.4	0.6	0.4	0.6	6.8
C	B	FL (3) 10 S	0.5	0.5	0.5	0.5	7.5
C	7	FL (3) 10 S	0.5	1.5	0.5	1.5	5.5
D	B	FL (3) 10 S	0.6	0.6	0.6	0.6	7.0
D	7	FL (3) 10 S	1.0	1.0	1.0	1.0	5.0
3	8	FL (2+1) 10 S	0.5	0.7	0.5	2.1	5.7
8	9	OC (3) 10 S	5.0	1.0	1.0	1.0	1.0
B	B	Q (3) 10 S	0.3	0.7	0.3	0.7	7.7
D	8	FL (2 + 1) 10 S	0.5	0.5	0.5	0.5	6.5
1	B	FL (3) 12 S	0.5	1.5	0.5	1.5	7.5
E	A	FL (3) 12 S	0.5	2.0	0.5	2.0	6.5
E	7	FL (3) 12 S	0.8	1.2	0.8	1.2	7.2
B	6	FL (3) 12 S	1.0	1.0	1.0	3.0	5.0
4	8	FL (2+1) 12 S	0.8	1.2	0.8	2.4	6.0
5	8	FL (2+1) 12 S	1.0	1.0	1.0	4.0	4.0
1	8	FL (2+1) 13.5 S	1.0	1.0	1.0	4.0	5.5
F	7	FL (3) 15 S	0.3	1.7	0.3	1.7	10.7
9	D	FL (3) 15 S	0.4	1.0	0.4	1.0	11.8
0	8	FL (3) 15 S	0.5	1.5	0.5	1.5	10.5
F	8	FL (2+1) 15 S	0.6	0.3	0.6	0.3	11.8
0	9	FL (2+1) 15 S	0.7	0.5	0.7	0.5	10.7
1	9	FL (2+1) 15 S	0.7	0.7	0.7	0.7	10.1
6	8	FL (2+1) 15 S	1.0	2.0	1.0	5.0	5.0
1	C	VQ (3) 15 S	0.1	0.5	0.1	0.5	13.7
4	B	FL (3) 20 S	0.5	3.0	0.5	3.0	12.5
3	B	FL (3) 20 S	0.5	1.5	0.5	1.5	15.5
5	B	FL (3) 20 S	0.8	1.2	0.8	1.2	15.2
6	B	FL (3) 20 S	1.0	1.0	1.0	1.0	15.0

SWITCH	FLASH CODE	ON	OFF	ON	OFF	ON	OFF	ON	OFF
A	B								
B	F	VQ (4) 4 S	0.25	0.25	0.25	0.25	0.25	0.25	2.25
B	D	Q (4) 6 S	0.3	0.7	0.3	0.7	0.3	0.7	2.7
8	D	Q (4) 6 S	0.4	0.6	0.4	0.6	0.4	0.6	2.6
1	D	FL (4) 10 S	0.5	1.0	0.5	1.0	0.5	1.0	5.0
2	D	FL (4) 10 S	0.8	1.2	0.8	1.2	0.8	1.2	3.2
F	E	Q (4) 10 S	0.3	0.7	0.3	0.7	0.3	0.7	6.7
B	E	FL (4) 12 S	0.3	1.7	0.3	1.7	0.3	1.7	5.7
4	F	FL (4) 12 S	0.5	0.5	0.5	0.5	0.5	0.5	8.5
C	E	FL (4) 12 S	0.5	1.5	0.5	1.5	0.5	1.5	5.5
3	D	FL (4) 12 S	0.8	1.2	0.8	1.2	0.8	1.2	5.2
A	D	Q (4) 12 S	0.3	0.7	0.3	0.7	0.3	0.7	8.7
4	D	FL (4) 15 S	0.5	1.5	0.5	1.5	0.5	1.5	8.5
8	E	FL (4) 15 S	1.0	1.0	1.0	1.0	1.0	1.0	8.0
7	D	FL (4) 15 S	1.5	0.5	0.5	0.5	0.5	0.5	10.5
D	E	FL (4) 16 S	0.5	1.5	0.5	1.5	0.5	1.5	9.5
C	D	FL (4) 20 S	0.3	3.0	0.3	3.0	0.3	3.0	9.8
5	D	FL (4) 20 S	0.5	1.5	0.5	1.5	0.5	1.5	13.5
0	D	FL (4) 20 S	0.5	1.5	0.5	1.5	0.5	4.5	10.5
3	F	FL (4) 20 S	1.5	1.5	1.5	1.5	1.5	1.5	9.5
0	F	Q (4) 20 S	0.5	0.5	0.5	0.5	0.5	0.5	16.5
E	E	Q (4) 28 S	0.5	0.5	0.5	0.5	0.5	0.5	24.5
6	F	FL (4) 30 S	0.5	0.5	0.5	0.5	0.5	0.5	26.5



SWITCH	FLASH CODE	ON	OFF	ON	OFF	ON	OFF	ON	OFF	ON	OFF	
A	B											
D	D	Q (5) 7 S	0.3	0.7	0.3	0.7	0.3	0.7	0.3	0.7	0.3	2.7
E	D	Q (5) 10 S	0.3	0.7	0.3	0.7	0.3	0.7	0.3	0.7	0.3	5.7
E	8	FL (5) 16.5 S	5.0	1.5	0.5	1.5	0.5	1.5	0.5	1.5	0.5	3.5
5	F	FL (5) 20 S	0.5	0.5	0.5	0.5	0.5	0.5	0.5	0.5	0.5	15.5
9	F	FL (5) 20 S	0.8	1.2	0.8	1.2	0.8	1.2	0.8	1.2	0.8	11.2
9	E	FL (5) 20 S	1.0	1.0	1.0	1.0	1.0	1.0	1.0	1.0	1.0	11.0

SWITCH	FLASH CODE	ON	OFF	ON	OFF	ON	OFF	ON	OFF	ON	OFF	ON	OFF
A	B												
F	D	Q (6) 10 S	0.3	0.7	0.3	0.7	0.3	0.7	0.3	0.7	0.3	0.7	4.7
A	F	FL (6) 15 S	0.3	0.7	0.3	0.7	0.3	0.7	0.3	0.7	0.3	0.7	9.7
7	F	FL (6) 15 S	0.5	1.0	0.5	1.0	0.5	1.0	0.5	1.0	0.5	1.0	7.0
A	E	FL (6) + LFL 15 S	0.5	1.0	0.5	1.0	0.5	1.0	0.5	1.0	0.5	1.0	7.0

SWITCH	FLASH CODE	ON	OFF	ON	OFF	ON	OFF	ON	OFF	ON	OFF	ON	OFF	ON	OFF	
A	B															
6	E	VQ (6) + LFL 10 S	0.2	0.3	0.2	0.3	0.2	0.3	0.2	0.3	0.2	0.3	0.2	0.3	2.0	5.0
7	E	VQ (6) + LFL 10 S	0.3	0.3	0.3	0.3	0.3	0.3	0.3	0.3	0.3	0.3	0.3	0.3	2.0	4.4
2	F	Q (6) + LFL 15 S	0.2	0.8	0.2	0.8	0.2	0.8	0.2	0.8	0.2	0.8	0.2	0.8	2.0	7.0
2	E	Q (6) + LFL 15 S	0.3	0.7	0.3	0.7	0.3	0.7	0.3	0.7	0.3	0.7	0.3	0.7	2.0	7.0
3	E	Q (6) + LFL 15 S	0.6	0.6	0.6	0.6	0.6	0.6	0.6	0.6	0.6	0.6	0.6	0.6	2.0	5.8
8	F	VQ (6) + LFL 15 S	0.3	0.3	0.3	0.3	0.3	0.3	0.3	0.3	0.3	0.3	0.3	0.3	2.0	9.4

SWITCH	FLASH CODE	ON	OFF	ON	OFF	ON	OFF	ON	OFF	ON	OFF	ON	OFF	ON	OFF	ON	OFF	ON	OFF	
A	B																			
4	E	VQ (9) 10 S	0.2	0.3	0.2	0.3	0.2	0.3	0.2	0.3	0.2	0.3	0.2	0.3	0.2	0.3	0.2	0.3	0.2	5.8
5	E	VQ (9) 10 S	0.3	0.3	0.3	0.3	0.3	0.3	0.3	0.3	0.3	0.3	0.3	0.3	0.3	0.3	0.3	0.3	0.3	4.9
1	F	Q (9) 15 S	0.2	0.8	0.2	0.8	0.2	0.8	0.2	0.8	0.2	0.8	0.2	0.8	0.2	0.8	0.2	0.8	0.2	6.8
0	E	Q (9) 15 S	0.3	0.7	0.3	0.7	0.3	0.7	0.3	0.7	0.3	0.7	0.3	0.7	0.3	0.7	0.3	0.7	0.3	6.7
1	E	Q (9) 15 S	0.6	0.6	0.6	0.6	0.6	0.6	0.6	0.6	0.6	0.6	0.6	0.6	0.6	0.6	0.6	0.6	0.6	4.8

SWITCH	FLASH CODE	ON	OFF	ON	OFF	ON	OFF	ON	OFF
A	B								
MORSE CODE ( ) INDICATES LETTER									
7	8	MO (A) 6 S	0.3	0.6	1.0	4.1			
7	B	MO (A) 8 S	0.4	0.6	2.0	5.0			
8	8	MO (A) 8 S	0.8	1.2	2.4	3.6			
B	8	MO (U) 10 S	0.3	0.7	0.3	0.7	0.9	7.1	
C	8	MO (U) 10 S	0.4	0.6	0.4	0.6	1.2	6.8	
D	8	MO (U) 10 S	0.5	0.5	0.5	0.5	1.5	6.5	
9	8	MO (A) 10 S	0.5	0.5	1.5	7.5			
8	9	MO (D) 10 S	5.0	1.0	1.0	1.0	1.0	1.0	
A	8	MO (A) 15 S	0.5	1.5	2.0	11.0			
F	8	MO (U) 15 S	0.6	0.3	0.6	0.3	1.4	11.8	
0	9	MO (U) 15 S	0.7	0.5	0.7	0.5	1.9	10.7	
1	9	MO (U) 15 S	0.7	0.7	0.7	0.7	2.1	10.1	
7	D	MO (B) 15 S	1.5	0.5	0.5	0.5	0.5	0.5	10.5

## Trouble Shooting

Problem	Remedy
Lantern will not activate.	<ul style="list-style-type: none"> <li>• Ensure internal toggle switch is set to the 'ON position.</li> <li>• Ensure lantern is in darkness.</li> <li>• Wait at least 60 seconds for the program to initialise in darkness.</li> <li>• Ensure switch setting is on a valid code (<i>See p8 – 14 of manual</i>).</li> <li>• Ensure battery terminals are properly connected.</li> <li>• Ensure battery voltage is above 3.4volts.</li> </ul>
Timing codes will not change.	<ul style="list-style-type: none"> <li>• Turn rotary switches several times to ensure contacts are clear.</li> </ul>
Lantern will not operate for the entire night.	<ul style="list-style-type: none"> <li>• Expose lantern to direct sunlight and monitor operation for several days. Sealite products typically require 1.5 hours of direct sunlight per day to retain full autonomy. From a discharged state, the lantern may require several days of operational conditions to 'cycle' up to full autonomy.</li> <li>• Reducing the light output intensity or duty cycle (flash code) will reduce current draw on the battery.</li> <li>• Ensure solar module is clean and not covered by shading during the day.</li> </ul>
Lanterns are constantly on during the day.	<ul style="list-style-type: none"> <li>• Ensure the flash code is not set to F F. This flash code is for testing purposes only and will be steady on for 24 hours a day.</li> </ul>
Lanterns are not synchronizing together. (Affects SL70-CS)	<ul style="list-style-type: none"> <li>• The lanterns will take up to 3minutes to synchronize with the surrounding lanterns.</li> <li>• If you have a large number of lanterns, they may start 'syncing' in groups. It may up to take 20 minutes for all lights to achieve full synchronization. This is dependent on the distance between the entire set of lanterns, the closer the lanterns, the quicker full synchronization will occur.</li> <li>• Ensure every light is set to the same flash code. Lanterns will only synchronize to lanterns using the same flash code.</li> <li>• Ensure the line of sight between 2 lanterns is clear on any obstruction. Trees, buildings, other structures or vessels will affect the lanterns ability to synchronize.</li> <li>• Ensure the lanterns are no more than 1.5km apart over water.</li> </ul>

All SL70-CS lanterns are fitted with a red Status LED. This is found near the Flash Code Switches. It helps determine a fault with the unit depending on the flash rate of the Status LED.

<b>Flash Rate</b>		<b>Mode</b>	<b>Status</b>	<b>Condition</b>
<b>On (sec.)</b>	<b>OFF</b>			
Steady	Off	Off	Normal	Normal running condition in daylight.
1/10	1	On	Normal	Lantern is not synchronised to other lanterns.
1	1	On	Normal	Lantern is synchronised to surrounding lanterns.
Steady	On	Off	Flat Battery	Battery is flat.
1/10	1/10	On	Low Battery	Battery is low.
1	2/10	On	Factory Set.	Unit is in factory setup mode (FF). Change flash code.



## Sealite Lantern Warranty

### *Activating the warranty*

Upon purchase, the Sealite warranty must be activated for recognition of future claims. To do this you have two (2) options:

1. Postal registration
  - Please complete the Sealite Warranty Registration card and return to Sealite within 30 days of your purchase.
2. Online registration
  - Please complete the Online Registration form at;

[www.sealite.com.au](http://www.sealite.com.au) or [www.sealiteusa.com](http://www.sealiteusa.com)

Sealite Pty. Ltd. will repair or replace your lantern in the event of electronic failure for a period of three years from the date of purchase.

The unit must be returned to Sealite Pty. Ltd. freight prepaid.

### Warranty Conditions

1. The warranty is applicable to lanterns manufactured from 1/1/2000.
2. The lantern must be installed in accordance with Sealite instructions.
3. No modifications to the original specifications determined by Sealite shall be made without written approval of Sealite Pty. Ltd.
4. Input voltage shall not exceed those recommended for the product.
5. Warranty does not cover damage caused by the incorrect replacement of battery in the SL15, SL60 or SL70 lantern models.
6. Replacement of battery is excluded from the warranty.
7. No recognition shall be given to flooding, or damage incurred from misuse of lanterns.
8. Solar modules are covered by individual manufacturers' warranty.

Information in this manual is subject to change without notice and does not represent a commitment on the part of the vendor. Sealite products are subject to certain Australian and world-wide patent applications.



#### **Head Office**

Sealite Pty Ltd  
11 Industrial Drive  
Somerville, Vic 3912  
Australia  
Tel: +61 3 5977 6128  
Fax: +61 3 5977 6124  
Email: [info@sealite.com.au](mailto:info@sealite.com.au)  
Internet: [www.sealite.com.au](http://www.sealite.com.au)

#### **USA Customers:**

GulfRim Navigation  
1401 South State  
Abbeville, LA 70510  
USA  
Ph: 877-893-0789  
Fax: 337-893-6256  
Internet: [www.gulfrim.com](http://www.gulfrim.com)  
Email: [info@gulfrim.com](mailto:info@gulfrim.com)